

west gate

MIND
MILANO INNOVATION DISTRICT

Zenith



Welcome to MIND - Milano Innovation District

A new milanese District
and a model of urban
regeneration responding
to a vision of innovation
and sustainable quality
of life



Imagine if...

▶ **PLAY VIDEO**

1 mln SQM
surface area

335,000 SQM (SLP)
public anchors

100,000 SQM (SLP)
other public space

480,000 SQM (SLP)
Private Development -
Mixed use real estate

€2.6 bn
Gross Development Value

2030
target completion

 200,000 SQM of grade a offices (GLA)

 20,000 SQM of co-working (GLA)

 120,000 SQM of laboratories and light industrial (GLA)

 1,500 BTR or serviced apartments

 1,100+ student accomodation beds

 35,000 SQM of retail (GLA)

 600 hotel rooms

 **PROJECT TARGETS**
to deliver project in line with Resilient Cities Index

 40 HECTARES of public open space

 €50m+ investment in revenue generating infrastructure

 €20m venture and social impact investing

 60,000 people living and working

 500+ innovation focused workers within the Village from 2021

 10,000 daily users of hospital fully operational in 2021/2022



MIND benefits from Milan's excellent infrastructure and transportation



METRO DISTANCES

10min	M1 M5	Lotto
20min	M1 M2	Cadorna
24min	M1 M3	Duomo

TRAIN DISTANCES

12min	Centrale station
16min	Garibaldi station
25min	Cadorna station

LINES

S5	Varese-Milano-Treviglio
S6	Novara-Milano-Treviglio
S11	Chiasso-Como-Milano-Rho

HIGH-SPEED RAIL DISTANCES

2h 47min	Venezia Santa Lucia
38min	Torino Porta Susa
3h 20min	Roma Termini

AIRPORT DISTANCES

20min	Malpensa
30min	Linate
45min	Orio al Serio

GALEAZZI-SANT'AMBROGIO HOSPITAL
(OPERATIONAL)

State of the art IRCCS hospital with over 500 beds

CASCINA TRIULZA
(OPERATIONAL)

Existing heritage building dedicated to social association and activities

VILLAGE PAVILION
(OPERATIONAL)
Designtech Innovation Hub

Federated innovation
MIND

HUMAN TECHNOPOLE
(OPERATIONAL, FORECAST COMPLETION: 2028)
Life Sciences Research Centre

UNIVERSITY OF MILAN
(FORECAST COMPLETION: 2026)
University of Milan's Science Campus

TRANSPORT HUB
Rho Fiera Milano

(OPERATIONAL)
Metro, Regional and High Speed Rail



MIXED USE ZONE 3
(FORECAST COMPLETION: 2031)
Commercial Workspace, Build-to-Rent, Light Industrial, Hotel and Placemaking Retail

MIXED USE ZONE 2
(FORECAST COMPLETION: 2028)
Commercial Workspace, Build-to-Rent, Light Industrial, Hotel and Placemaking Retail

MIND MERLATA STOP
(FORECAST COMPLETION: 2026)
Location of Second Passante Stop

west gate

FORECAST COMPLETION:
2025 first part, 2027 second part

Commercial Workspace, Build-to-Rent, Light Industrial, Hotel and Placemaking Retail

MINDVILLAGE

OPERATIONAL FROM:
2022

Commercial Workspace, Laboratories, Retail, Amenities and Marketing Suite

- COMMERCIAL
- RESIDENTIAL
- RETAIL
- HOTEL
- LIGHT INDUSTRY-LAB
- STUDENT HOUSING
- PUBLIC PROGRAMME
- PUBLIC PROGRAMME PARKS
- PARKING
- TECHNOPOLO

Zenith & Molo

e-on



arexpo
URBAN INNOVATION

Fondazione
Trulza

HUMAN
TECHNOPOLE

UNIVERSITÀ
DEGLI STUDI
DI MILANO

IRBM BRACCO Trevisan & Cuonzo ARITHMOS INDACO Milano Stand
 CONTEC aqs HV embecta ARISK Deerns coopservice
 elements AdvicePharma DISTRETTO 33 UMANA promeia

lendlease e-on elt ELECTRONICA world's the top address GDMH cdp DIGITAL BLCOM Welltech Innovation

Berkeley SKYDECK
+ PLUSVALUE

DIESSE

illumina ROLD TIM
ANYTIME FITNESS Bio4Dreams

Carri
FADOI

ESSELUNGA AstraZeneca

Designtech CONTEC GRUPPO CARIPLO+FACTORY federated innovation MIND

Podium planeateco

Carri
planeateco

Botticino VALORE ITALIA

Visionary corporates
have already chosen
MIND as their home.
They are the minders

Discover your neighbors



BARANZATE
RHO

lendlease e-on elt GDMH cdp DIGITAL BLCOM WellTech Innovation

IRBM BRACCO Trevisan & Cuonzo ARITHMOS UMANA Berkeley SKYDECK
concec aqs HV embecta ARISK +PLUSVALUE
elements AdvicePharma DISTRETTO 22 promeida FADOI
INDACO Milano Stand Deerns coopservice DIESSE

Fondazione Triulza

arexpo

MINDVILLAGE

I.R.C.C.S. Ospedale Galeazzi - Sant'Ambrogio Gruppo San Donato

Galeazzi-Sant'Ambrogio Hospital

Cascina Triulza

C1

The Hive

Village Pavilion

HUMAN TECHNOPOLE

Designtech CONTEC GARIPLO+FACTORY federated innovation MIND

west gate

planeat.eco

Food court

The Value

VALORE ITALIA Botticino CIMA

Cocoon

Paddock

Studio1

Podium planeat.eco

e-on

illumina ROLD Bio4Dreams TIM ANYTIME FITNESS

AstraZeneca ESSELUNGA

MIND has opened its doors to the public in 2022 and it is continuing its development

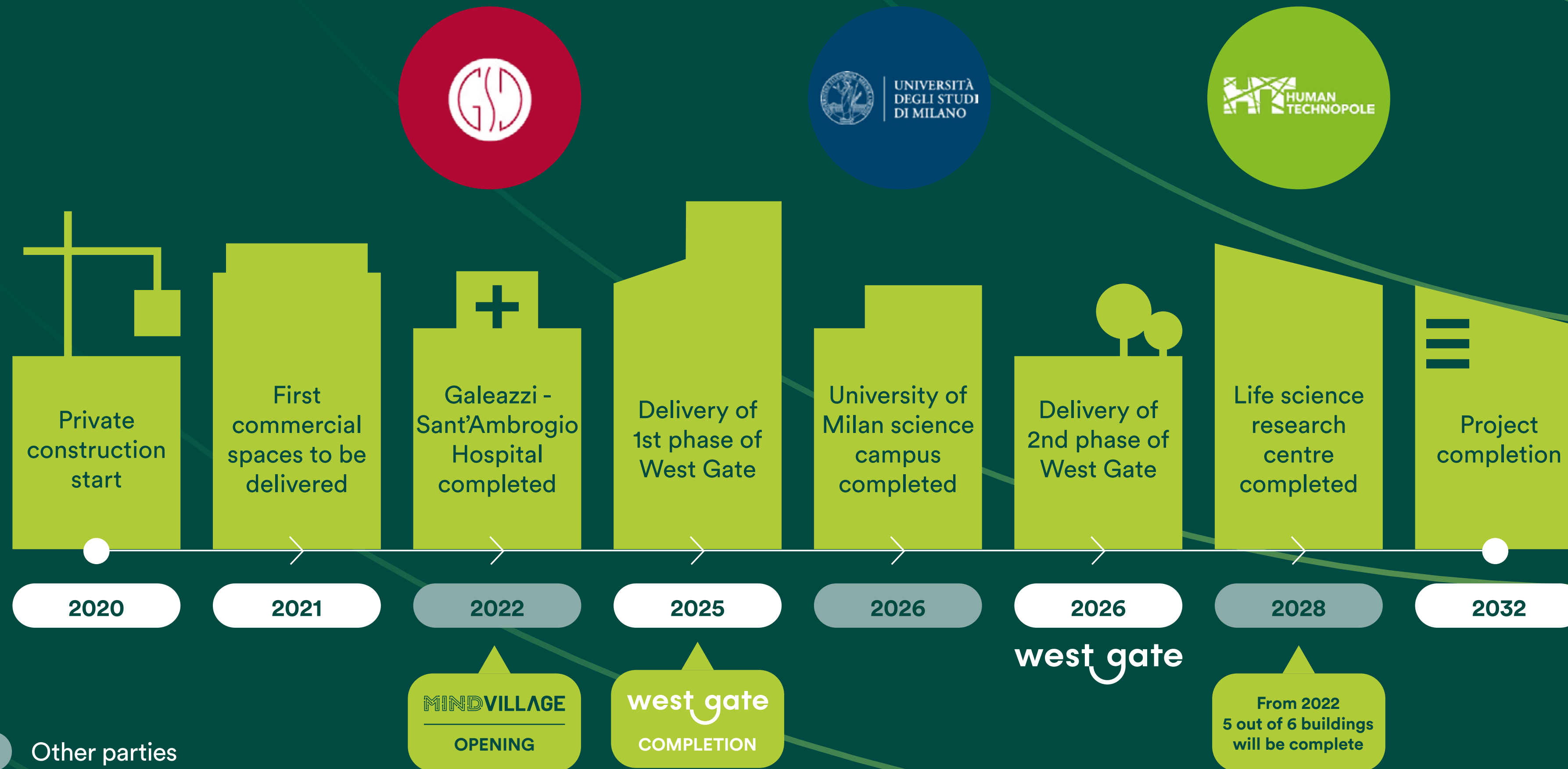

Placemaking strategy

PHASE 1

PHASE 2

PHASE 3

OCT 21



VILLAGE PHASE 1

Open areas for activation and sport activities become active during summer time for activities and networking. Areas are designed to be flexible based on needs and season.

JUN 22



VILLAGE SOUTH

Introduce area with temporary interventions and light activation, aligned with the community and future needs. MIND community puts down roots to bring new ideas to live.

AUG 23



VILLAGE NORTH

Q4 25



WEST GATE PHASE 1

Q4 25



PARK PHASE 1

The Park is accessible and open to the public, increasing outdoor activities and spaces supporting the wellbeing. MIND community becomes to grow and to target the wider Milanese community.



WEST GATE PHASE 2

First mixed used development opening. Offices, residential, retail F&B, innovation spaces, services are available to increase footfall and to make MIND more attractive.

Existing services

Phase 1, convention to be negotiated

	Service	Location	Deadline
🍴	Restaurants		
	Freeway Route 66	Rho	Q2 23
	Dodicivolte Trattoria	Rho	Q2 23
	Pasticceria Palma	Rho	Q2 23
	Antica Cascina	Baranzate	Q2 23
	A modo mio	Baranzate	Q2 23
	Pizzeria MZMTR	Pero	Q2 23
+	Extra services		
	International School of Milan	Baranzate	Q2 23
	Car Wash	Baranzate	Q3 23
🏃	Sports&Fun		
	Molinello Play Village	Rho	Q2 23
	Pero Sporting Club	Pero	Q2 23
	AeroGravity	Pero	Q3 23
	UrbanWall + Skate Park	Pero	Q3 23
	Verisport Padel&Calcetto	Rho	Q3 23
💇	Beauty&Selfcare		
	Studio Relab	Rho	Q2 23
	Nouvelle Estetique	Rho	Q2 23
	Shampoo Rho	Rho	Q2 23
	BH Hair Salon	Baranzate	Q3 23
🏠	Pharmacy		
	Farmacia Varesina	Baranzate	Q2 23
	Farmacia Cuttone	Rho	Q2 23

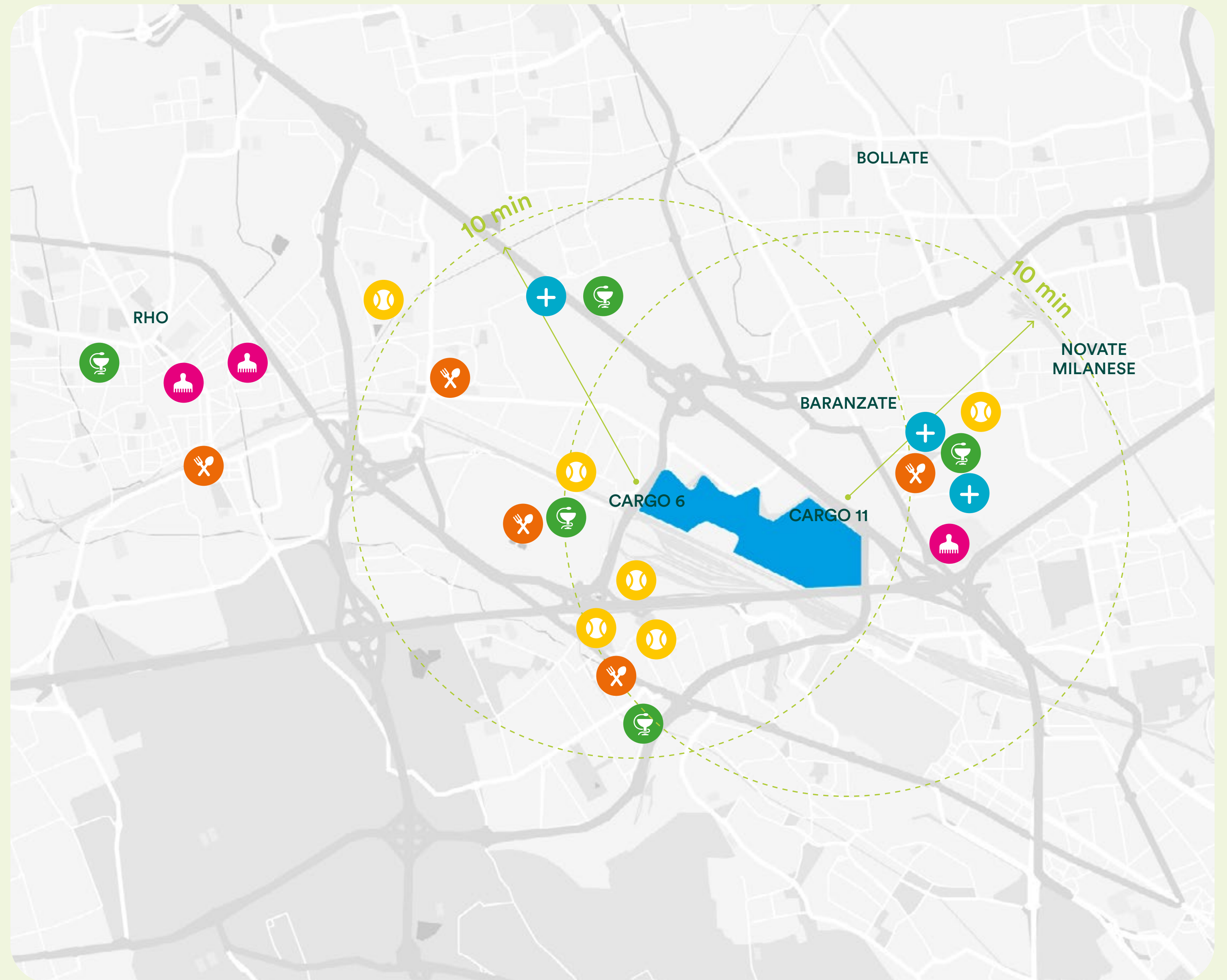

MIND Services: phasing and programme 2023-24

Today, MIND already has a comprehensive set of services available (laundry, bookshop, pharmacy) as well as multiple food and beverage options (café, restaurants and food delivery).

MIND has significant **coworking and conference room** offering (from 4-seat meeting room to 400-seat auditorium).

In the short term, plan is to further implement with pop up retail and additional activation services. Significant retail facilities available in neighboring **il Centro – Arese** (operational, 9 mins by car) and **Merlata Bloom** shopping center (opening Q4, 23 with direct connection to MIND planned in line with UniMi delivery).

SERVICES (ACTIVE TODAY)

1. Amazon / Food Lockers
2. Laundry pick up
3. ATM
4. EV charger
5. Car sharing
6. Weekly market
7. Dressing room
8. Bookshop, Travel agency, Cafè, Pharmacy (Galeazzi Hospital)
9. Sport equipment locker
10. Food delivery (zeroimpack)

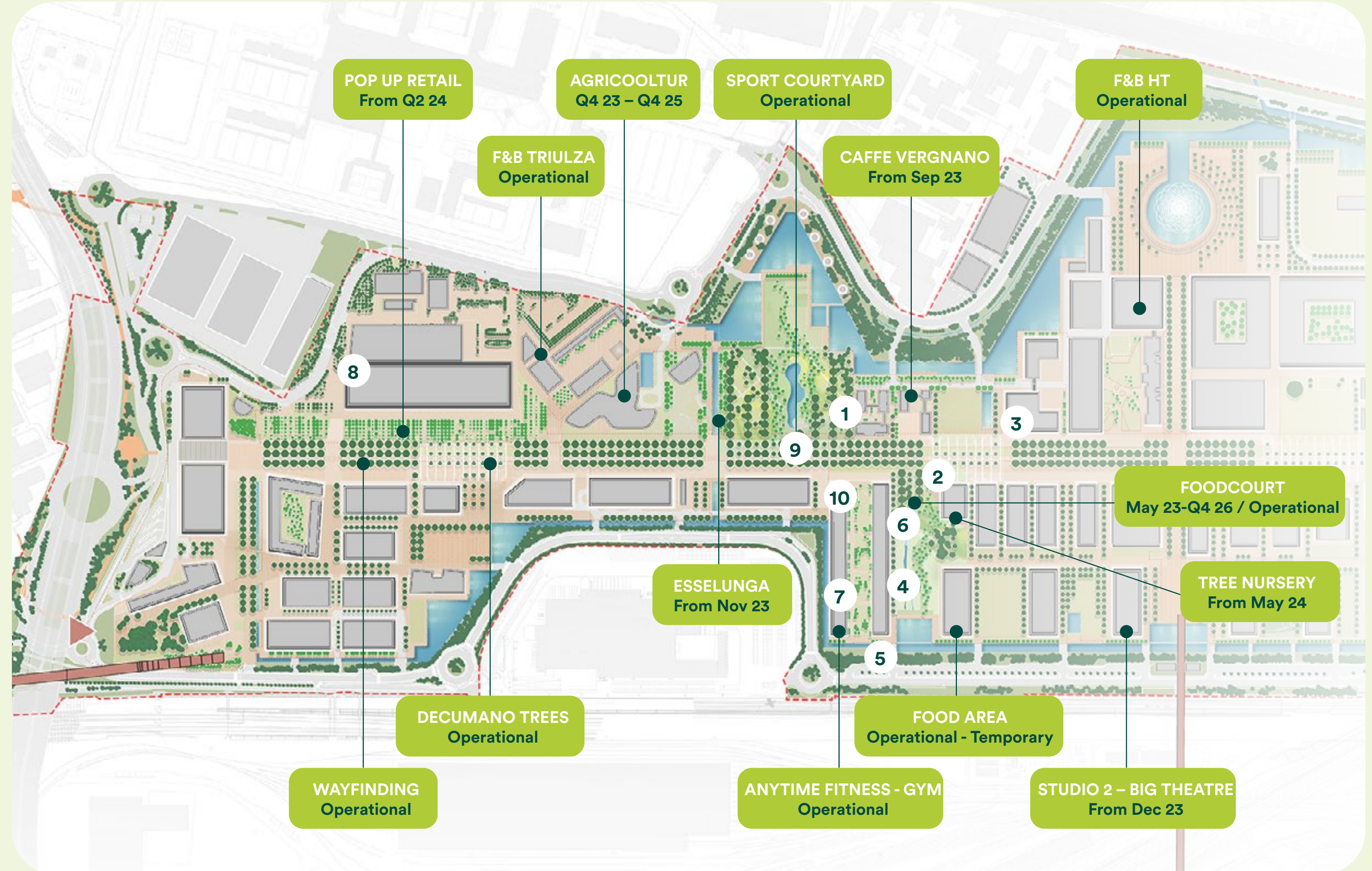

MIND Ecosystem

A global excellence
in lifescience
to propel innovation

Seven anchors are driving MIND's development and will catalyze an influx of innovative companies and excellent projects



The leading research institute for life sciences in Italy.



The leading hospital for orthopaedic and prosthetic surgery.



Public teaching and research University, top performer in the Life Sciences domain.



Innovation network for the third sector.



Innovation ecosystem of private entities in partnership with key public authorities.



Public scientific-technological University, leader in teaching and research.



Arexpo owns the area where Expo Milano 2015 was held and has the task of developing MIND.

Federated Innovation@MIND is a space for innovation, a partnership of private and public entities born to turbocharge innovation in Lifescience and City of the Future.

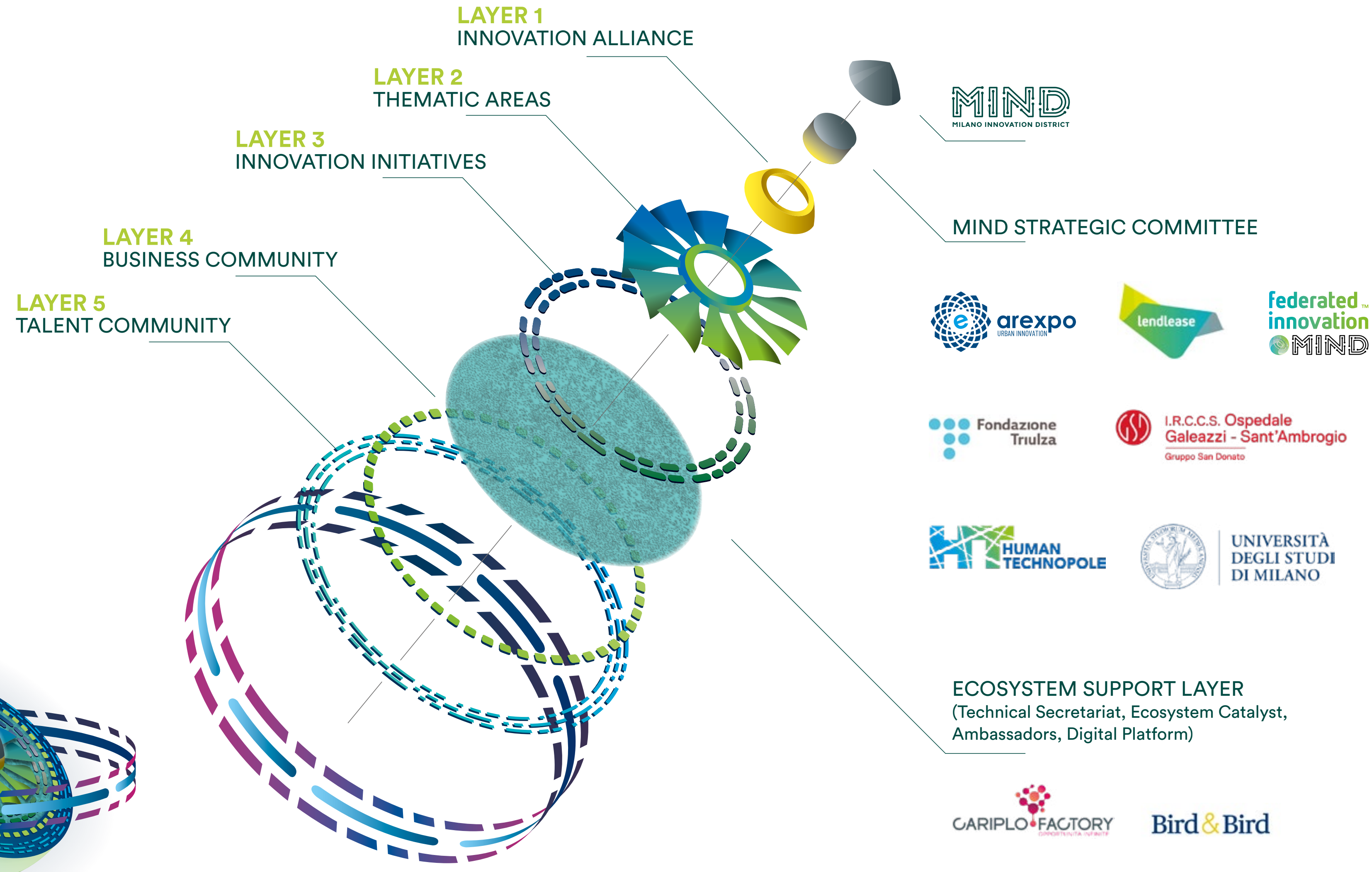
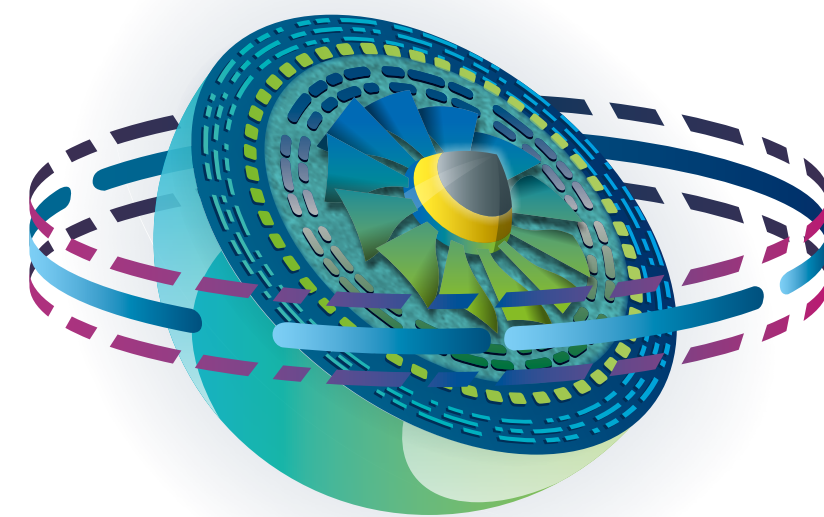
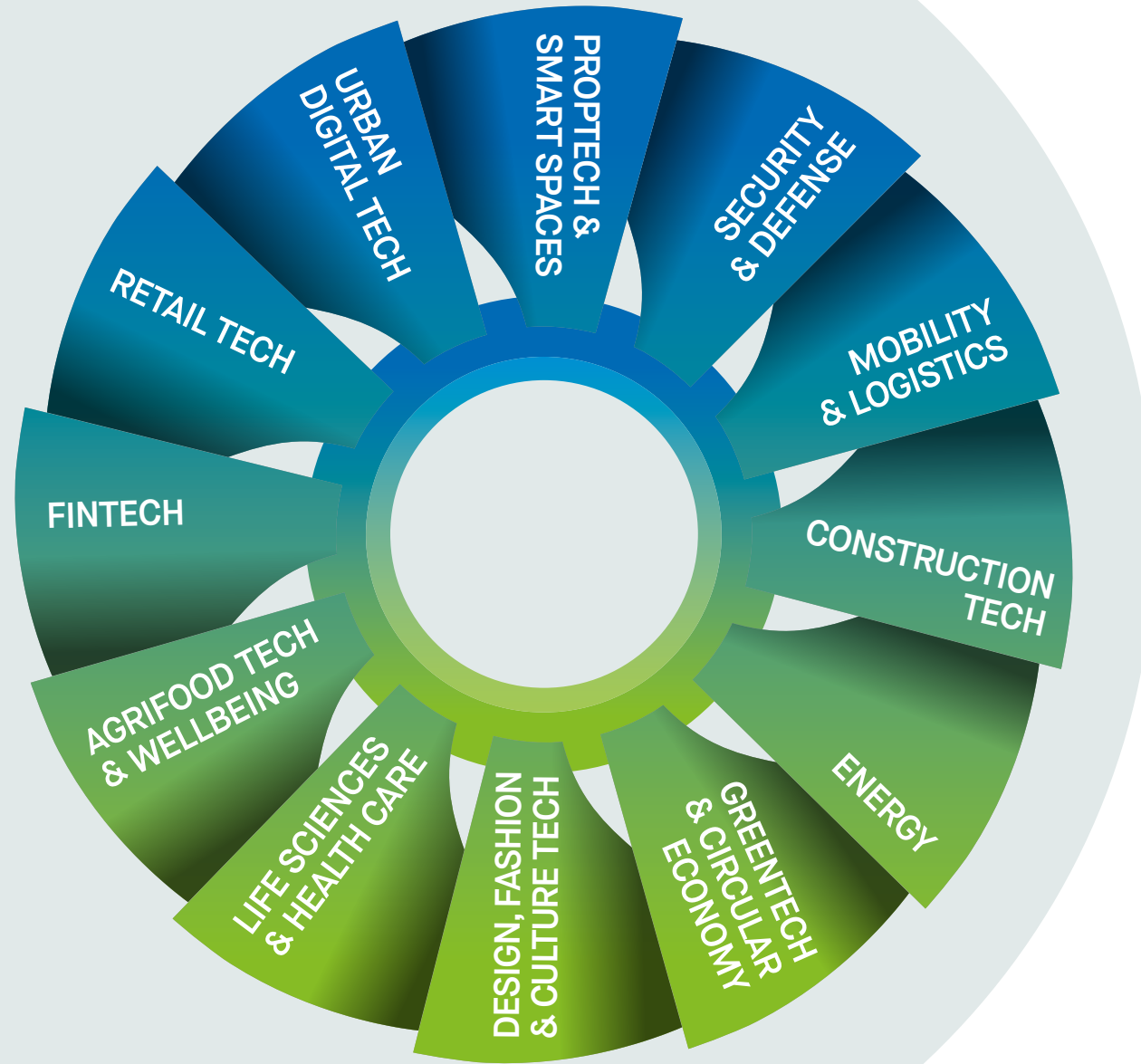

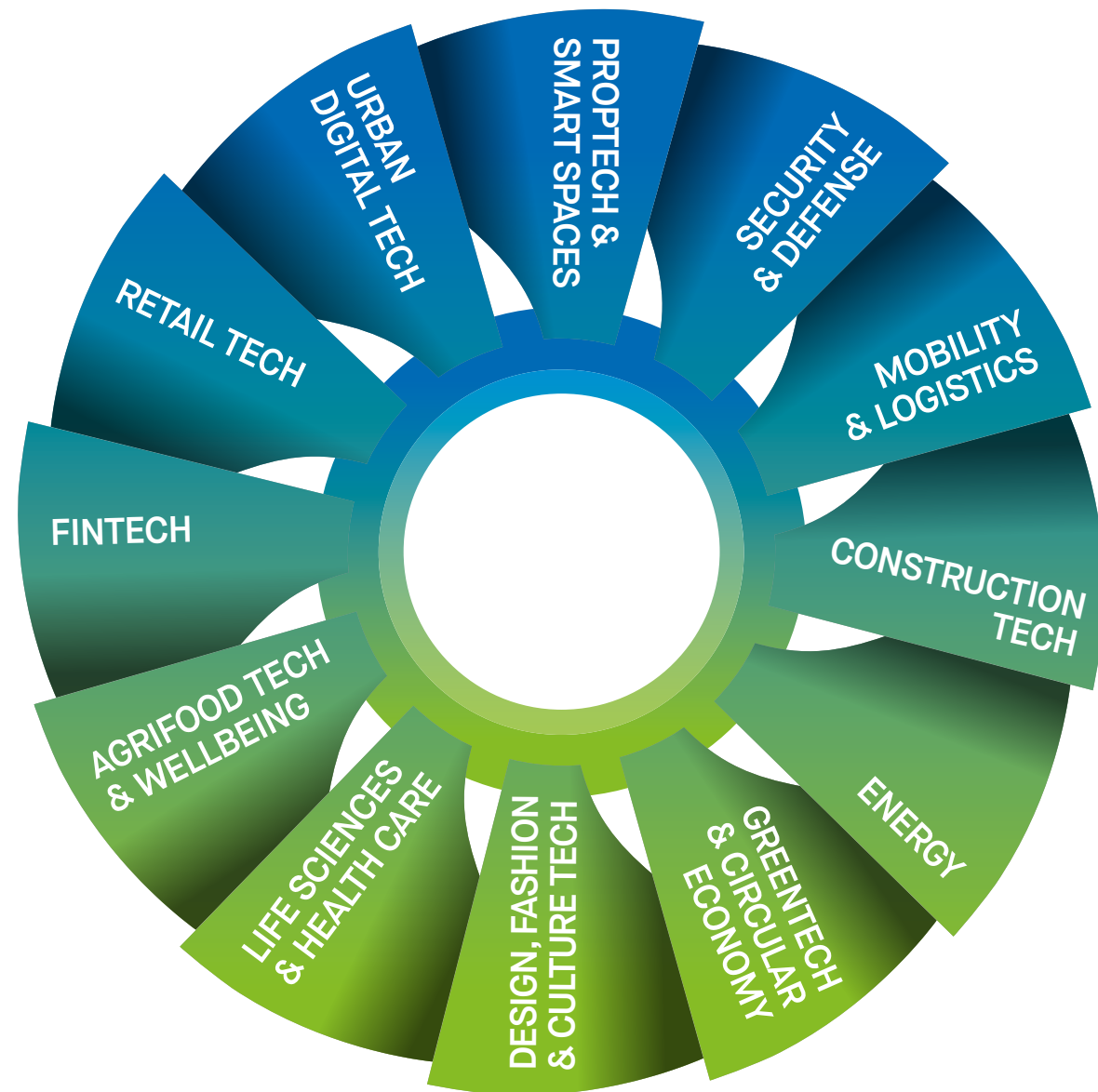

+ 5000
Average Employees

+48%
Women employed

+31%
Women presence at Board level

+2M €
Average budget for R&D

+40,000 €
Average budget for Federated Innovation projects

Federated Innovation @MIND Members per Thematic areas

AGRIFOOD TECH & WELLBEING



CONSTRUCTION TECH



ENERGY



FINTECH



GREENTech & CIRCULAR ECONOMY



LIFE SCIENCES & HEALTH CARE



MOBILITY AND LOGISTICS



PROPTech & SMART SPACES



RETAIL TECH



SECURITY & DEFENSE



URBAN DIGITAL TECH



DESIGN, FASHION & CULTURE TECH



WestGate: Nurturing innovation every day

The first mixed-use
milestone
carrying the whole
District's vision



**Welcome to West Gate,
the place to stay, work, live,
connect and enjoy**

MOLO
To work

Office GLA	2,837 sqm
Office GLA	6,375 sqm
Retail GLA	2,700 sqm
Total GLA	17,450 sqm

WG HOSPITALITY
To stay

WG LIVING
To live

ZENITH
To work

Office GLA	20,767 sqm
Retail GLA	640 sqm
Total GLA	21,407 sqm

HORIZON
To work

Office GLA	20,218 sqm
Total GLA	20,518 sqm

INNOVATION HUB
To work

Office GLA	7,075 sqm
Retail GLA	760 sqm
Total GLA	7,835 sqm

COMMON GROUND
To enjoy



West Gate benefits from **key location**, **accessibility** and **infrastructure**

The project has an excellent connection thanks to both private and public means of transports which are located within the major regional infrastructure system.

Also, MIND is part of a larger development area that includes the mixed used development of Cascina Merlata and that will generate a new Milanese destination.



WestGate will reshape your experience of urban life: come find your way of working, living, connecting and enjoying

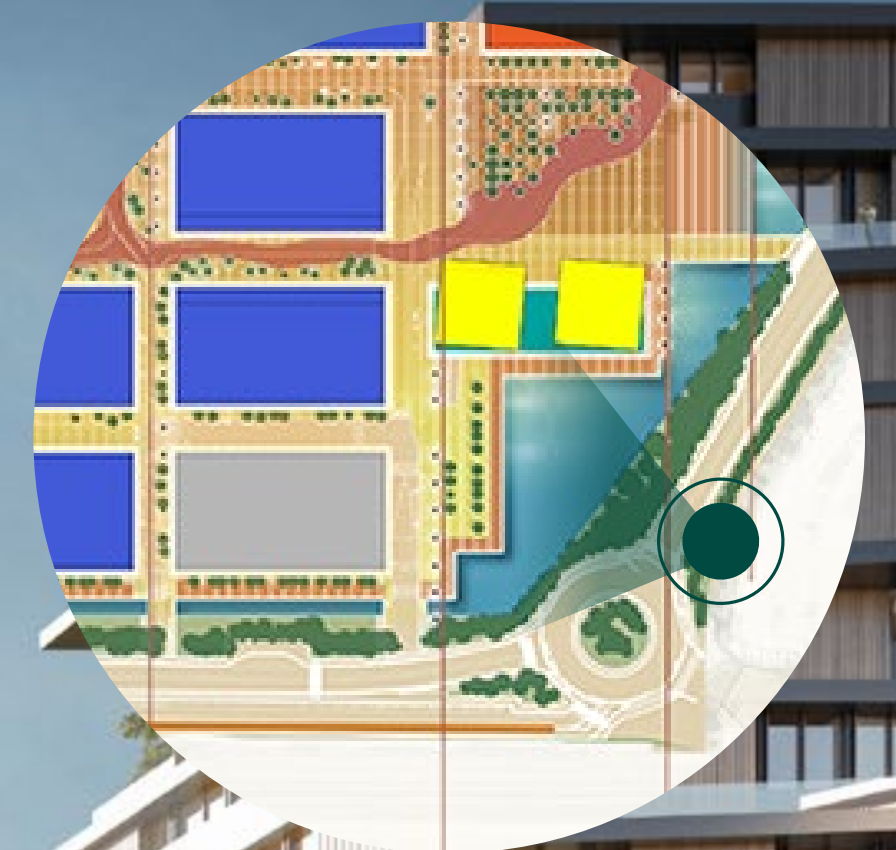

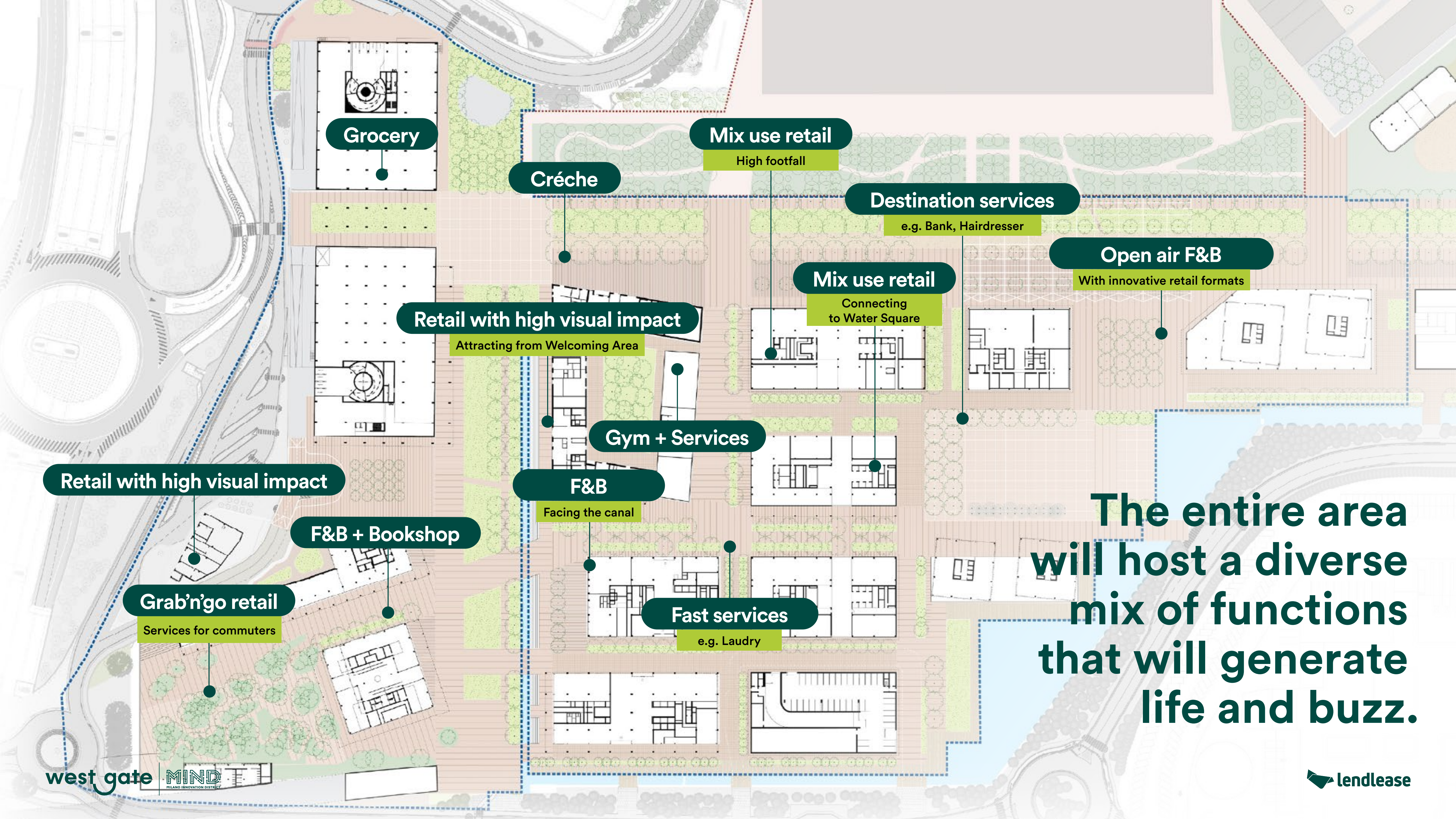

Grocery

Mix use retail

High footfall

Crèche

Destination services

e.g. Bank, Hairdresser

Open air F&B

With innovative retail formats

Mix use retail

Connecting to Water Square

Retail with high visual impact

Attracting from Welcoming Area

Gym + Services

F&B

Facing the canal

Fast services

e.g. Laundry

Retail with high visual impact

F&B + Bookshop

Grab'n'go retail

Services for commuters

The entire area will host a diverse mix of functions that will generate life and buzz.

Something to do, all over the day



Services
22%



Health
& Beauty
4%

F&B
26%



Mobility
8%



Households
14%



F&B Refuel
6%

Personal
items
17%



Electronics
3%



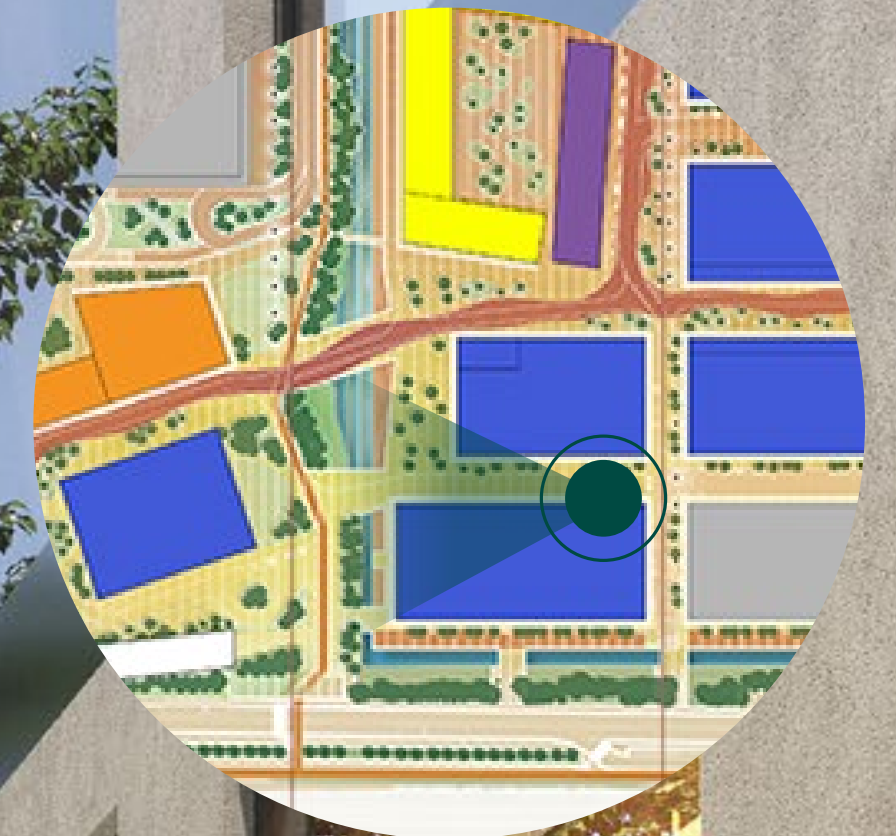

Cycle/pedestrian and public transport access

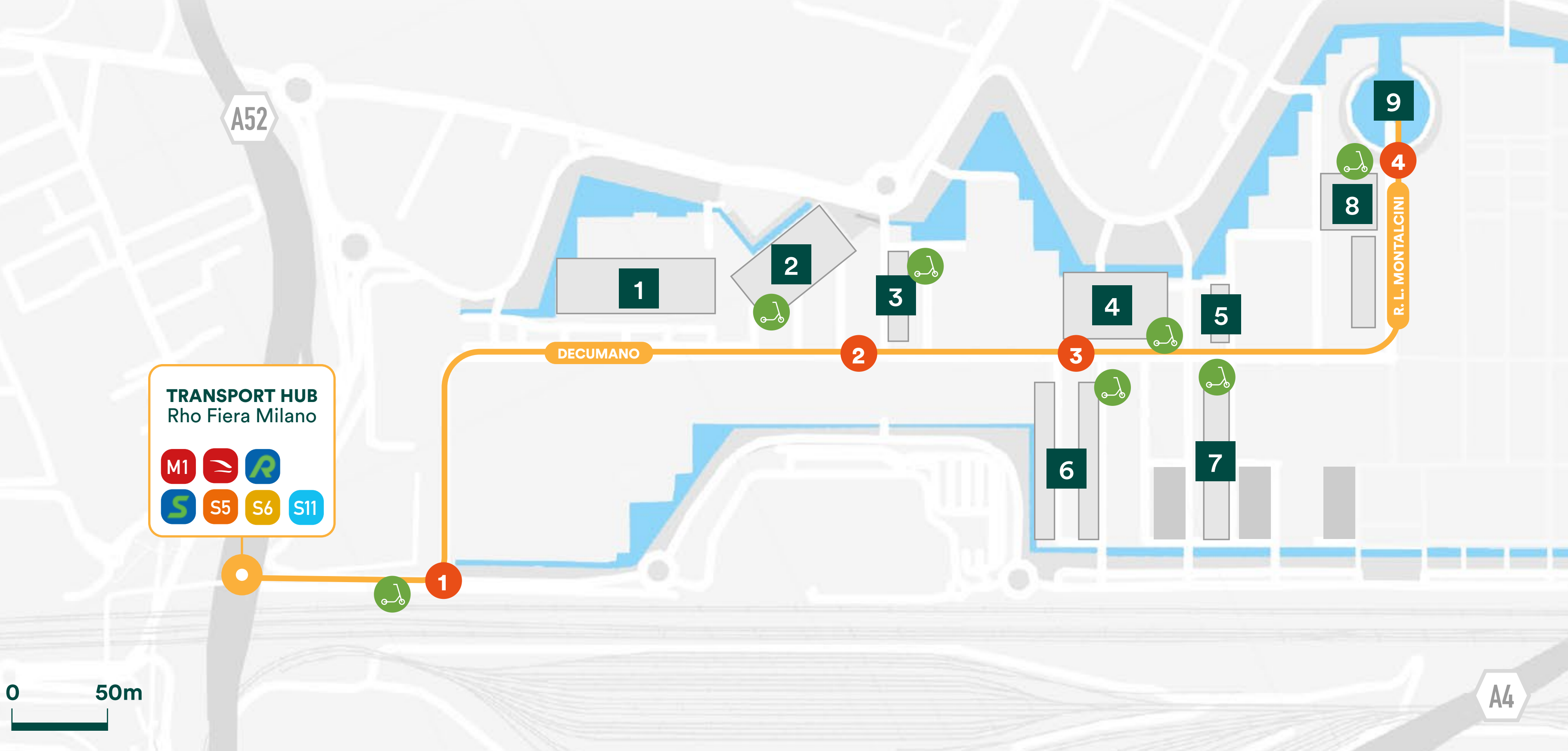

	1 IRCCS Ospedale Galeazzi - Sant'Ambrogio
	2 Cascina Triulza
	3 Digital Bloom
	4 The Hive
	5 Village Pavilion
	6 Cocoon & Paddock
	7 The Value
	8 Human Technopole
	9 Piazza Expo 2015

TRANSPORT HUB
Rho Fiera Milano



CYCLE/PEDESTRIAN ACCESS

FROM MM1:
Go down at Rho Fiera (MM1), beyond gates turn right and go through the tunnel till the end.

FROM TRAIN STATION:
Reach the end of the tunnel beyond platform 6, then follow the yellow tunnel at your right. Follow the yellow flow on the ground to reach MIND Shuttle stop 1. TheShuttle is free to navigate the site.

MIND SHUTTLE STOPS

-
- 1 Transport Hub
 - 2 Cascina Triulza - Arexpo - C1
 - 3 Mind Village
 - 4 Palazzo Italia - Human Technopole

SCOOTER PICK-UP POINTS

Inside MIND it is possible to move around with HELBIZ scooters.

Pick up your scooter at the pickup points and remember to park it in the appropriate spaces.

Services



A52

A8

A4



1		IRCCS Ospedale Galeazzi - Sant'Ambrogio
2		Cascina Triulza
3		Digital Bloom
4		The Hive
5		Village Pavilion
6		Cocoon & Paddock
7		The Value
8		Human Technopole
9		Piazza Expo 2015

Services are accessible for the general public during MIND opening time. Events and activities at MIND are included within MIND Village App.

<p>AUDITORIUM</p> <p>Large spaces for conferences, meetings and events</p> <ul style="list-style-type: none"> Ospedale Galeazzi Cascina Triulza Media Hall Palazzo Italia 	<p>PLAYGROUND AREA</p> <p>Space dedicated to sport activity</p> <ul style="list-style-type: none"> 2 basketball fields 1 volleyball field Chess Ping Pong 	<p>SERVICE POINT</p> <p>Inside you will find:</p> <ul style="list-style-type: none"> Laundry room 	<p>FOOD COURT</p> <p>Space dedicated to tasting and meeting</p> <ul style="list-style-type: none"> Bar Restaurant 	<p>COMMON AMENITIES</p> <ul style="list-style-type: none"> Water house Fountain EV charger Bike racks Changing room
--	--	--	--	--

MIND will be an urban pilot for the european green transition.

It will bring together the public and private sector and the European Investment Bank to advance the following environmental criteria. Lendlease has established a series of indicators and monitoring tools to ensure that these ambitions are being realised on the way to absolute zero.

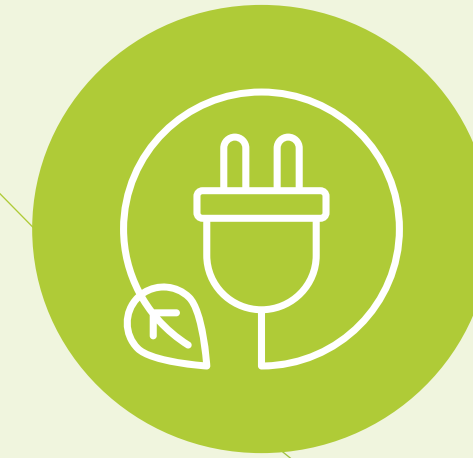

Energy performance

The whole electricity demand will be 100% renewable



Resource management

No waste approach and high standard recycling objective



Green mobility strategy

Fully electric transport onsite, walkable and cyclable routes



Water management strategy

Integrated strategy to reduce sitewide potable water demand



Embodied carbon in construction

50% reduction against RICs carbon footprint benchmarks



Resilience to extreme weather

Masterplan considers the effect of heat islands and urban flooding



One Health principles approach

MIND is designed to increase both people and planet's wellbeing



Engagement and behavioural change

Engaging audience to take the greenest and healthiest choices



Environmental impact transparency

Impact will be monitored and verified by third independent party

Using DfMA to construct MIND buildings, provides tenants with flexible and sustainable solutions.

EFFICIENT
Kit of standard parts

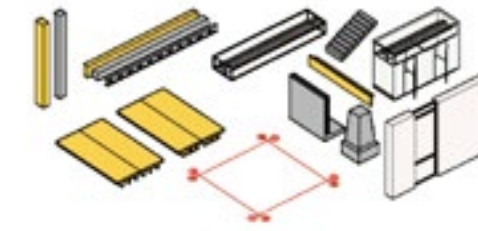

MORE SUSTAINABLE
Reduced waste, flexible and reusable components



IMPROVED ACCURACY
Fabrication in clean and controlled environments

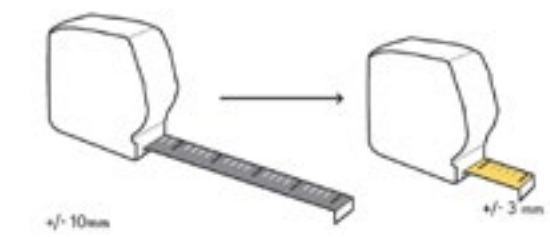

DESIGN FOR MANUFACTURING, ASSEMBLY, AND DISASSEMBLY

DfMA
Design for Manufacture and Assembly

100% WOODEN MATERIALS

SPEED
Time on site is reduced



FLEXIBILITY
Family of mix and match structural solutions

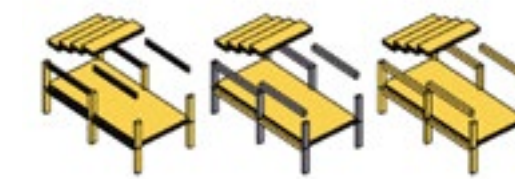

SAFETY
Reduction of trades on site

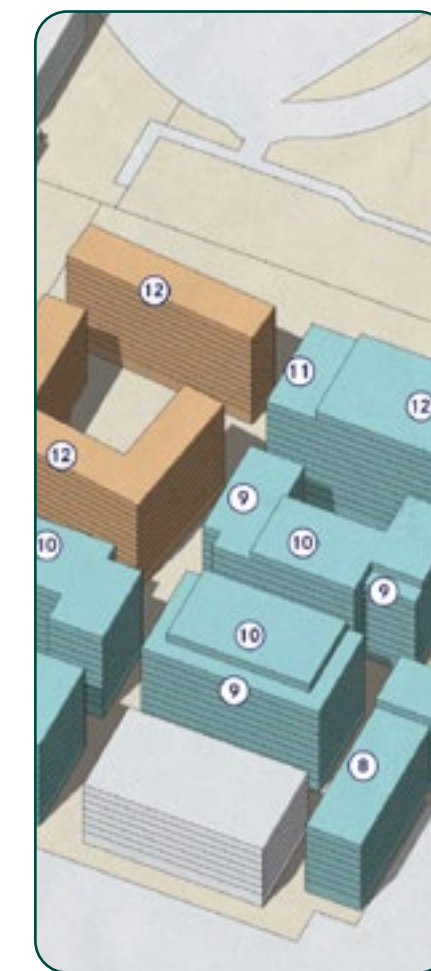
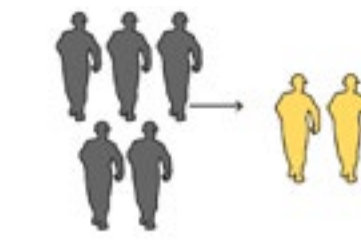

MASTERPLAN

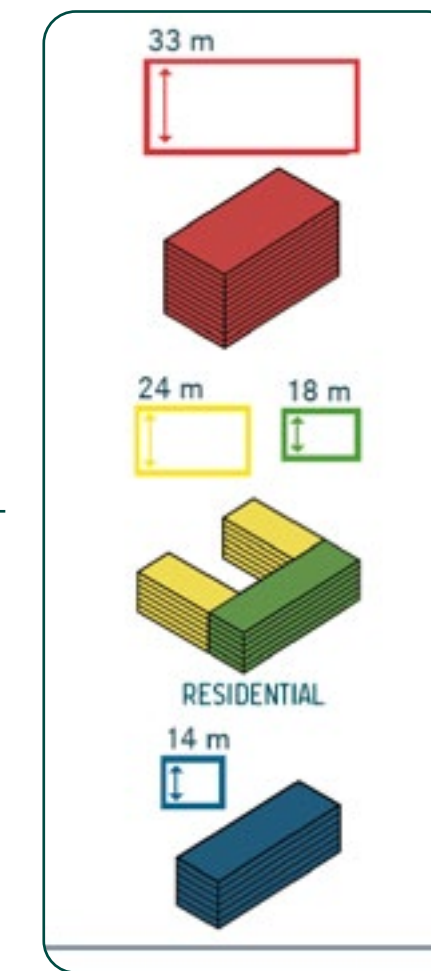

SUITE OF BUILDINGS



SUITE OF CORES

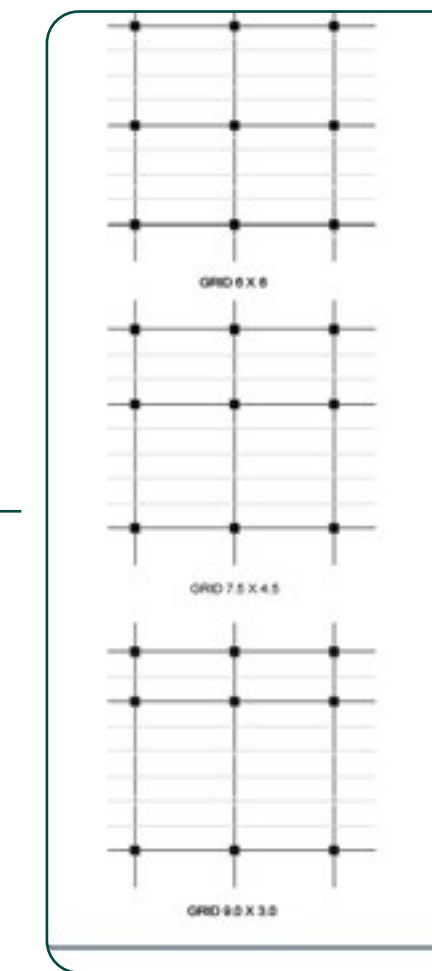

SUITE OF GRIDS

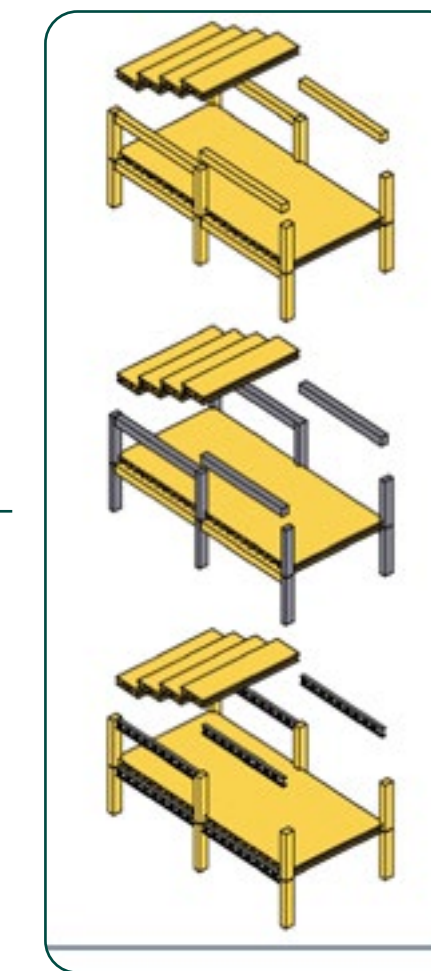

SUITE OF SYSTEMS

MIND office buildings will use **Cross laminated timber** as a principle material, with proven benefits in **sustainability, health and wellbeing and aesthetic.**

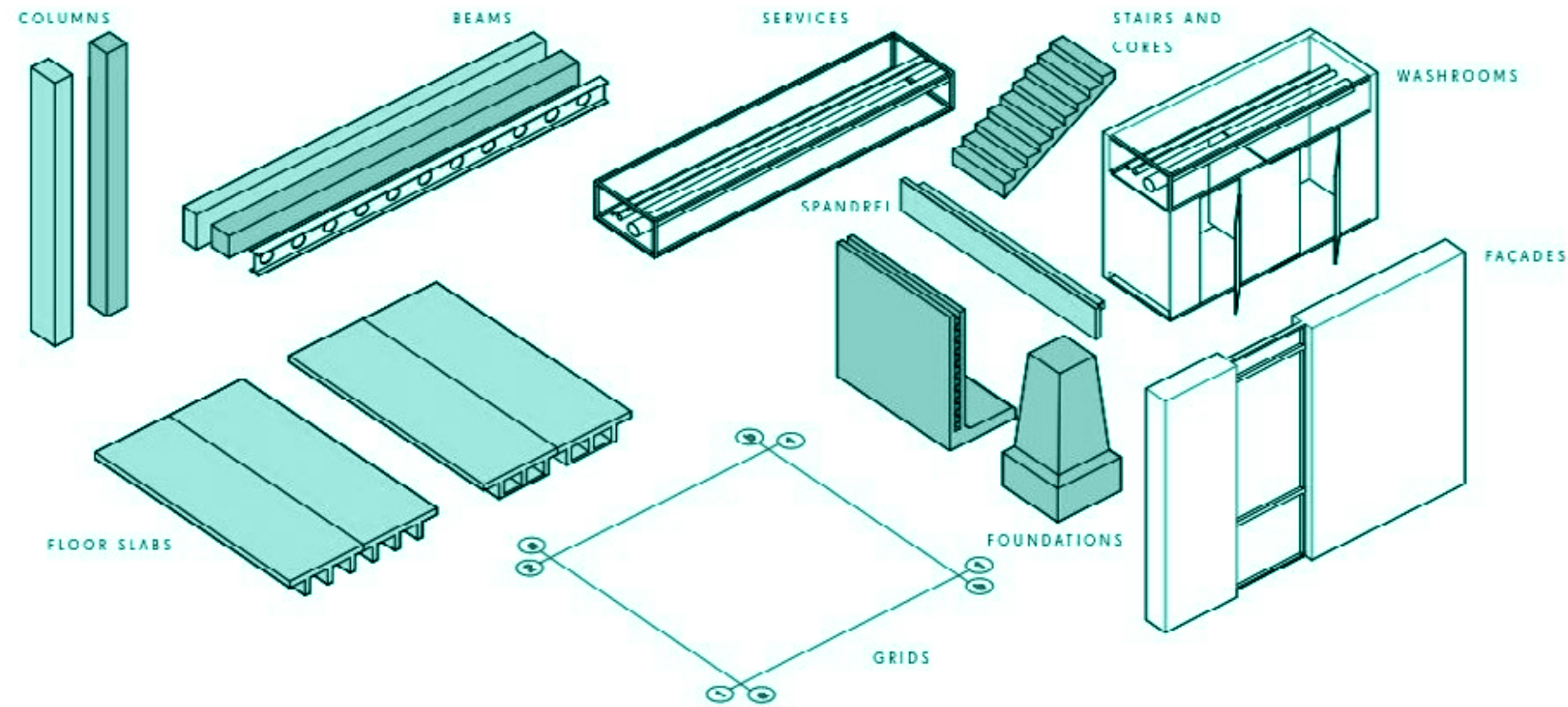

Lendlease has experience in delivering CLT office product and see an opportunity to pursue a hybrid timber design solution for MIND office plots. The hybrid approach is expected to maximise the timberness of the building through CLT beams and slabs in prepanel (a prefab timber hybrid system).



A CIRCULAR ECONOMY FOR BUILDING CONSTRUCTION, IN LINE WITH THE RESILIENT CITIES INDEX

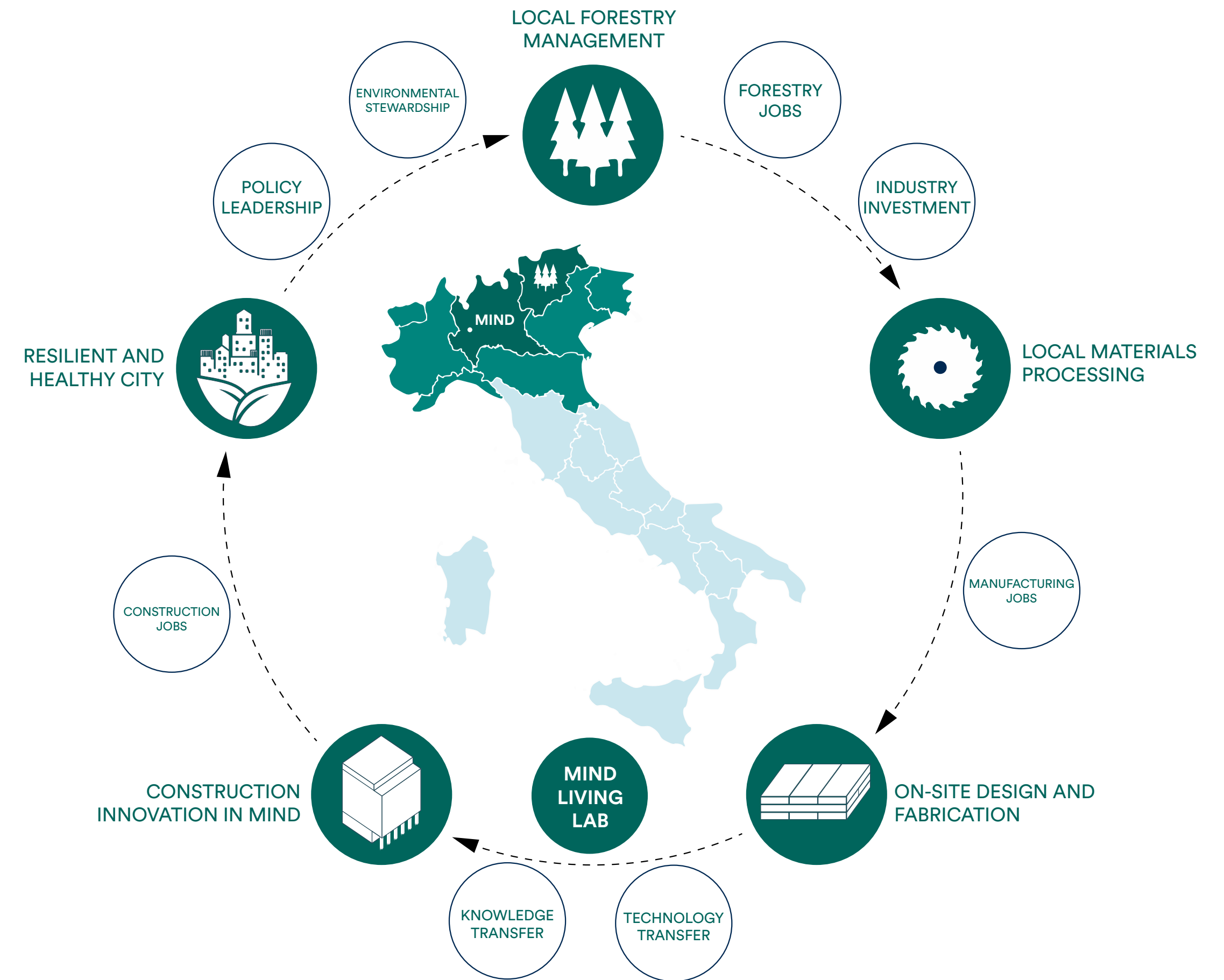

West Gate
office space

Where
ideas have
space to grow,
blossom
and spread

Zenith

To work



Zenith offers the perfect space for a new open, modern, exciting way of working

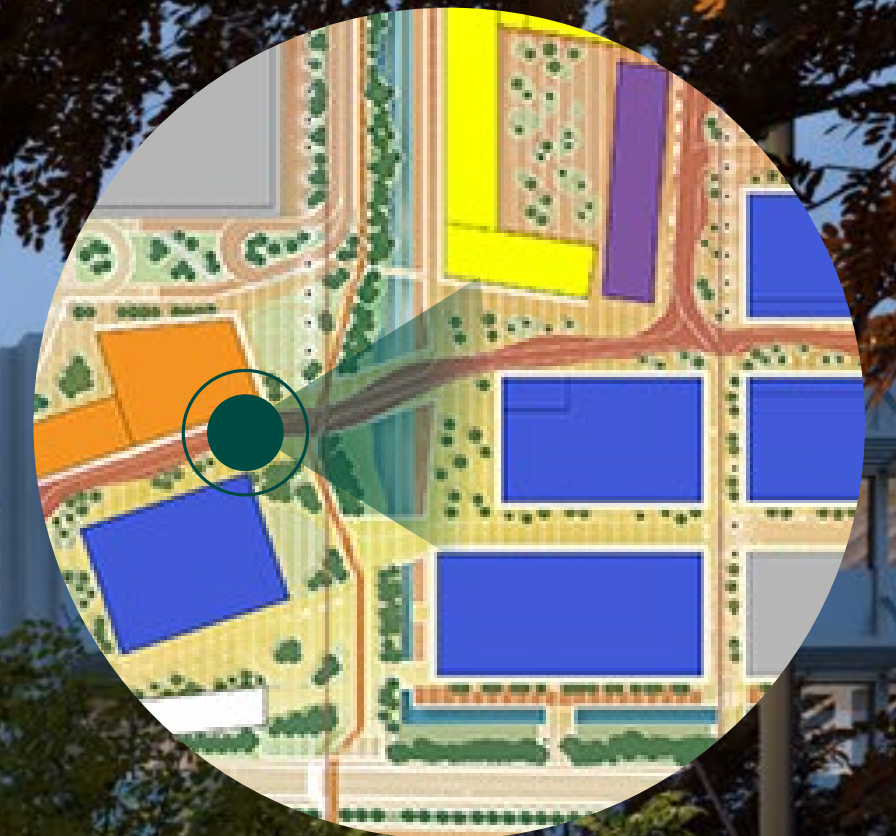



**Benefit from spaces
designed to foster cooperation
and help talents meet**



Light, air, green, openness...
Your vantage point
of a healthier workplace



Stacking plan

GLA sqm

12	Office	1,584
11	Office	1,584
10	Office	1,590
9	Office	1,736
8	Office	1,736
7	Office	1,736
6	Office	1,736
5	Office	1,736
4	Office	1,736
3	Office	1,736
2	Office	1,421
1	Office	1,539
0	Lobby	1,533
-1	Basement	1,177



Monotenant layout



● Toilets ● Stairways, elevators

- Support spaces:**
- 2 L meeting rooms
 - 2 M meeting room
 - 8 S meeting rooms
 - 2 phone booths
 - 1 quiet room
 - 2 copy areas
 - 1 informal meeting room
 - 1 wardrobe
 - 1 lockers room
 - 1 break area

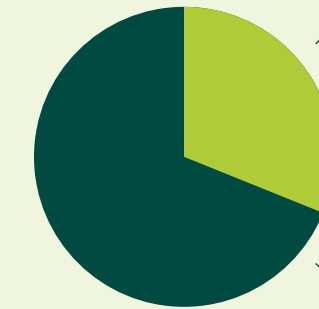

29%

71%

Work desks:
64 desks
16 closed offices

Open spaces

Closed spaces

80%

20%

Max floor crowding: **187**

Total desks: **98**

Bitenant layout



● Toilets ● Stairways, elevators

Tenant 1

Support spaces:
 1 L meeting room
 1 M meeting room
 1 S meeting room
 1 phone booths

1 quiet room
 1 copy area
 1 informal meeting room
 1 wardrobe
 1 lockers room
 1 break area

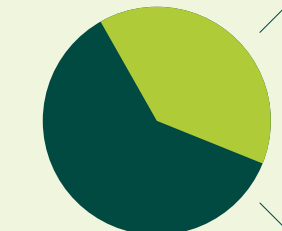

48%
52%

Work desks:
 48 desks
 4 closed offices
 2 reserved desks

Open spaces **92%** Closed spaces **8%**

Max floor crowding: **93** Total desks: **58**

Tenant 2

Support spaces:
 1 L meeting room
 1 M meeting room
 4 S meeting room
 1 modular meeting room

2 phone booths
 1 quiet room
 1 copy area
 1 informal meeting room
 1 wardrobe
 1 lockers room
 1 break area

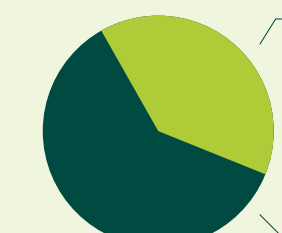

48%
52%

Work desks:
 32 desks
 2 reserved desks

Open spaces **100%**

Max floor crowding: **93** Total desks: **44**

Zenith

4.1.2

Offices: Class A Open spaces

LOCATION:

West Gate, MIND
Milano Innovation District
Milan Municipality

Metro every 4minutes to Duomo,
5 minute by train to/from Milano Centrale.
30 minutes to Linate, 35 minutes to Milano Malpensa Airport

PROPOSED COMPLETION DATE:

Q3 2025

TOTAL AREA GLA:

20,518 sqm (GLA Global - Revision 16)

Context

- Connectivity
- Public space
- Visibility
- Common ground

Low impact

- Passive Design
- Low Embodied Carbon
- Life Cycle Positive

Health & Wellbeing

- Green areas
- LEED, WELL, Wired Score
- Walkability

FLOOR PLATES:

Typical floor plates are approximately GLA: **2,349 sqm**
Maximum workplace density Nia: **1:8**
Efficiency Nia/Gia: **85%**
Soft spots for interconnecting stairs

BUILD QUALITY:

BOMA International Investment Class A
Shell & Core + Category A fitout including raised floor, finished lobby and amenities.
Provision for ceiling up to 2700 high, 3500 high.

TIMBER FLOOR DECKS:

Timber ribbed floor decks. Precast concrete columns and beams. Cast-in-situ concrete core walls; cast-in-situ concrete underground structure and foundation.

Building grid: 9x9m

AIR QUALITY:

Fresh air supply: **1.5 l/s m2**
with potential to increase to ≈ 2 l/s m2 on some floors (3).

Passive chilled beams and operable windows.

PRIVATE CARPARK BAYS:

184 bays available

Includes electric vehicles and car share spaces for entire building.

LIFTS AND SECURITY:

- Destination control
- Touchless access controls
- Designed to CIBSE Guide D standards

AMENITIES:

- Flex space
- Lobby
- Childcare

WEST GATE AMENITIES:

- Active ground floor
- End of trip facilities
- Childcare

ENVIRONMENTAL TARGETS:

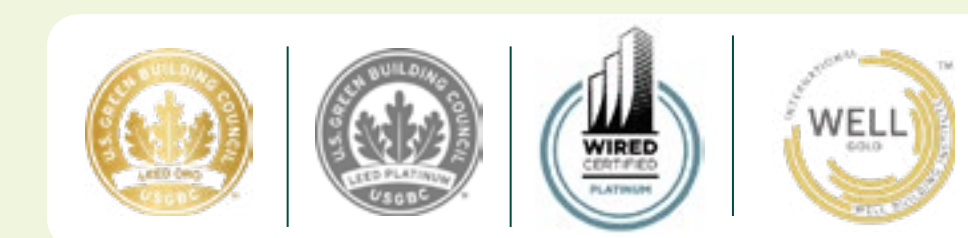

LEED: Gold & Platinum
WELL: Gold
WIRED: Platinum

Zenith

4.1.2

Offices: Class A Open spaces

ARCHITECTURE:

The permeable lobby is the building's distinctive element.

- The double-height glazing emphasises its visual permeability, just as the permeability of the pedestrian pathways within the building becomes an innovative element with respect to canonical urban space.

2 restroom blocks, 4 toilets + 1 handicap accessible toilet
6 lifts + 1 freight lift

STRUCTURES (DFMA):

The interior and elevated structure of the building (floors, beams and columns) are made of wood.

- Building designed considering a life cycle assessment and to respond positively to the Carbon Strategy.

basement and core: reinforced concrete

ground floor-2nd floor: beams and pillars are in reinforced concrete, while the floors are in wood

upper floors: the structure is made entirely of wood

The outdoor spaces on the roof will host air handling units

FLOORS:

raised, excluding floor finish (carpet, PVC or other)

11 cm sub-floor space

FALSE CEILINGS:

not envisaged, the systems will be visible on the wooden structure.

MECHANICAL PLANTS:

ACTIVE COLD BEAM HEATING AND COOLING
WITH BMS SYSTEM

SMOKE AND HEAT EVACUATION

DOMESTIC WATER SUPPLY

SEWERAGE AND RAINWATER DISCHARGE

PRESSURISATION OF SMOKE-PROOF FILTERS

FIRE EXTINGUISHING SYSTEM, WITH AUTOMATIC
EXTINGUISHING VIA DRY SPRINKLERS

LED LIGHTING WITH DALI SYSTEM

EVAC, CCTV, BMS, INTRUSION
AND ACCESS CONTROL SYSTEM

PHOTOVOLTAIC SYSTEM ON THE ROOF

CENTRALISED AIR TREATMENT SYSTEM

MECHANICAL VENTILATION AND EXTRACTION



Download the MIND Village app and discover all its fantastic features!



AMENITIES



FOOD DELIVERY



SPACES RESERVATION



PARKING



EVENTS



AND MUCH MORE!





Thank you

Disclaimer

This presentation has been prepared and issued by Lendlease Europe Holdings Limited (“LEHL”). None of LEHL, Lendlease, nor any of their respective associates or directors makes any warranties or representations regarding the timeliness, quality, accuracy or completeness of the information in this document. Recipients must make their own independent assessment, after making such investigations as they deem necessary (including independent analysis of any other information they consider relevant). This presentation does not constitute a recommendation by, or advice from LEHL, Lendlease, nor any of their respective affiliates, associates or any other person to any recipient of this presentation. Investors and recipients of this presentation must rely on their own representatives and advisers, including their own legal advisers and accountants, as to legal, tax and related matters.

In particular, any targets, projections, estimates, forecasts and opinions necessarily involve significant elements of subjective judgement, assumptions as to future events and analysis, which may or may not be correct and each recipient of this presentation should satisfy itself in relation to such matters. There are usually differences between projected and actual results and these differences may be material. Neither LEHL, Lendlease, nor any of their respective associates or directors guarantee the future success of any investments, the repayment of capital or any particular rate of capital or income return. Investment-type products are subject to investment risk, including the possible loss of capital invested. The information contained in this presentation is confidential and is provided for the exclusive use of the recipient.

This presentation may not be copied or distributed (except to the recipient’s professional advisers, who must be informed of its confidentiality) and the recipient and its professional advisers must keep confidential all matters contained within it which are not already in the public domain or subsequently become public other than through the fault of the recipient or its advisers.

By receiving and retaining this document, investors agree to be bound by and observe these confidentiality restrictions. Unless otherwise indicated, information contained in this presentation is current only as at the date of issue of this presentation.